

TRUS[≡]AL TSPe TSPi

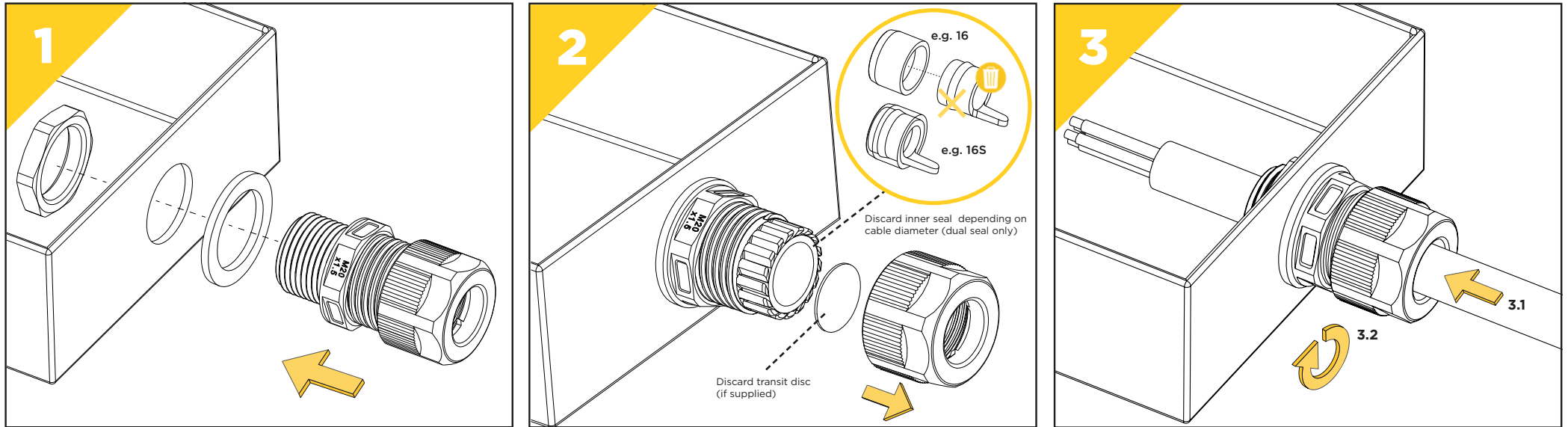

TSPe/TSPi Tightening Table																	
Number of turns	Gland Size																
	12	16SI	16DI	16DO	20SI	20DI	20DO	25SI/25DI	25DO	32SI/32DI	32DO	40SI/40DI	40DO	50SI/50DI	50DO	63SI/63DI	63DO
0.50							14.0	15.5	18.0			27.0	32.0	32.0	38.0	39.0	48.0
0.75				10.0			12.8	14.7	16.2	19.0	25.0	25.2	30.2	29.5	36.0	36.8	45.8
1.00	6.5	7.0	7.0	8.7	10.0	10.0	11.5	13.9	14.4	17.4	23.7	23.4	28.4	27.0	34.0	34.6	43.6
1.25	4.8	5.0	5.8	7.3	7.5	6.3	10.3	13.1	12.5	15.8	22.3	21.6	26.6	24.5	32.0	32.4	41.4
1.50	3.0	3.0	4.7	6.0	5.0	5.5	9.0	12.3		14.1	21.0	19.8	24.8	22.0	30.0	30.2	39.2
1.75			3.5					11.5		12.5	19.7	19.0	24.0		28.0	28.0	37.0
2.00			3.2					10.6			18.3						
2.25								9.8			17.0						
2.50								9.0									

Cable Diameter

FI605		
IFS	3	07/20
ATEX/IECEx	2	05/20

INCORPORATING EU DECLARATION OF CONFORMITY TO DIRECTIVE 2014/34/EU

TECHNICAL DATA

CABLE GLAND TYPE:	TSPe/TSPi
INGRESS PROTECTION:	IP66, IP67, IP68, IP69, IP69K
PROCESS CONTROL SYSTEM:	ISO 9001 ISO/IEC 80079-34:2011

EXPLOSIVE ATMOSPHERE CLASSIFICATION

ATEX CERTIFICATION No:	CML 19ATEX3185X, CML 19ATEX4186X
ATEX CERTIFICATION CODE:	Ⓔ II 2G Ex eb IIC Gb, II 1D Ex ta IIIC Da
IECEX CERTIFICATION No:	Ⓔ II 3G Ex nR IIC Gc
IECEX CERTIFICATION CODE:	IECEX CML 19.0062X Ex eb IIC Gb, Ex ta IIIC Da, Ex nR IIC Gc

IMPORTANT NOTES FOR INSTALLERS

- Read all instructions before beginning installation. Installation shall only be performed by competent, suitably trained personnel (in accordance with EN/IEC 60079-14) using the correct tools; spanners should be used for tightening. Special tools are available from CMP Products Limited to make installation easier.
- Inspection and maintenance shall only be performed by competent, suitably trained personnel (in accordance with EN/IEC 60079-14 (Initial Inspection) and EN/IEC 60079-17 (Electrical installations, inspections and maintenance).
- The interface between a cable entry device and its associated enclosure / cable entry will require additional sealing to achieve ingress protection (IP) ratings higher than IP54. The minimum protection level is IP54 for explosive gas atmospheres and IP6X for explosive dust atmospheres. All threads require a CMP sealing washer to maintain IP66, 67, 68 & 69 (K) when applicable. It is the installer's responsibility to ensure the IP rating is maintained at the interface.
- The standard product temperature range is -60°C to +95°C. The equipment should not be used outside of this range.
- Cable glands do not have any serviceable parts and are therefore not intended to be repaired.
- TruSeal cable glands are manufactured from both metallic and non-metallic materials with a halogen free thermoset elastomer seal. The non-metallic materials used in CMP Products cable glands are chemically resistant to most oils, fuels, spirits and some alcohols. The materials are not compatible with most acids. Please contact CMP Products to check compatibility with a particular chemical. For metallic materials, consideration should be given to potential degradation due to galvanic corrosion at the interface of dissimilar metallic materials. The end user shall consider the performance of these materials with regard to attack by aggressive substances that may be present in the hazardous area.
- It is the end user's responsibility to ensure the equipment materials are suitable for their final installation location. If in doubt consult CMP Products Limited.
- Once installed do not dismantle except for inspection. An inspection should be conducted as per IEC / EN 60079-17 by a qualified person. After inspection the gland should be re-assembled as instructed, ensuring the outer seal nut is correctly tightened to ensure the cable is secured.
- Metric entry threads comply with ISO 965-1 and ISO 965-3. The CMP standard metric thread pitch is 1.5mm for threads for these cable glands. See certificate for details of other thread types. NPT threads are in accordance with ASME B1.20.1-2013 gauging to CI 3.2 for external threads. For details of other thread types refer to the relevant certificate.
- The enclosure surface finish must be smooth and flat to facilitate sealing with an O-ring or Entry Thread Sealing Washer for the required IP rating.
- The enclosure will need to be sufficiently strong to support the cable and cable gland assembly. Enclosure entries must be perpendicular. Any draft angles from the casting/moulding process should have a perpendicular flat spot machined to facilitate sealing with an Entry Thread Sealing Washer.
- CMP Products recommends when using the cable gland with a through-hole, the hole must be circular, free of burrs and the diameter no larger than 0.2mm above the thread major diameter. A suitable CMP Products locknut shall be used to secure the product. See CMP Products catalogue for locknut options.

OPTIONAL IP PLUG INSTALLATION

To install the IP Plug, follow guidance up to Step 2 on the overleaf. Insert the IP Plug as per the image (for the dual inner seals, make sure the gap in the IP Plug aligns with the notch on the seal) then tighten as per the table below.

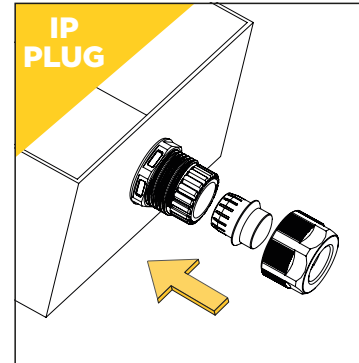

Size	Number of turns
12	0.5
16	0.5
20	0.5
25	0.5
32	0.5
40	0.5
50	0.5
63	0.5

SPECIFIC CONDITIONS OF USE

- The TruSeal TSPe/TSPi M12 & M16 Cable Glands have been tested to a mechanical impact of 4J and therefore shall only be installed where the risk of mechanical impact is low.
- The TruSeal Range of Cable Glands are only suitable for fixed installations. The end user shall provide suitable additional clamping of the cable to ensure that pulling is not transmitted to the terminations.
- When a TruSeal M12 TSPe/TSPi Cable Gland is installed where its service temperature exceeds +75°C, it shall be mounted such that it is adequately protected against the risk of mechanical impact.
- M40, M50 & M63 TSPe/TSPi Cable Glands - Under certain extreme circumstances may be a potential electrostatic charging hazard, clean only with a damp cloth

CMP Products Limited on its sole responsibility declares that the equipment referred to herein conforms to the requirements of the ATEX Directive 2014/34/EU and the following standards: -

EN IEC 60079-0:2018, EN IEC 60079-7:2015 + A1:2018, EN IEC 60079-15: 2019, EN 60079-31:2014, EN 62444:2013

J. Hichens

Jonathan Hichens - Lead Certification Engineer - (Authorised Person)
CMP Products Limited, Cramlington, NE23 1WH, UK
17th March 2020