

## ComEx Control and Indicating Devices

Typ 07-351\*-\*\*\*\*\*



# ComEx Control and Indicating Devices

Typ 07-351\*-\*\*\*\*\*



## Note on instructions

When working in hazardous areas, the safety of personnel and equipment depends on compliance with the relevant safety regulations. The people in charge of installation and maintenance bear a special responsibility. It is essential that they have an exact knowledge of the applicable rules and regulations.

The instructions provide a summary of the most important safety measures and must be read by everyone working with the product so that they will be familiar with the correct handling of the product.

The instructions have to be kept for future reference and must be available throughout the expected life of the product.

## Description

ComEx is a flexible system that offers both standardized and also customized local control and display stations.

The standard enclosures, single (07-3511-.../07-3514-...), double (07-3512-.../07-3515-...) and triple (07-3513-.../07-3516-...) can be combined with various actuators, switching modules, and luminous modules.

## Explosion protection

ATEX	Ex II 2 G Ex db eb IIC T6 Gb
Ex type of protection	Ex II 2 G Ex db eb ia IIC T6 Gb Ex II 2 D Ex tb IIIC T80 °C Db -55 °C ≤ Ta ≤ +60 °C CE 0044
Certification	CML 14 ATEX 3073X
IECEX	Ex db eb IIC T6 Gb
Ex type of protection	Ex db eb ia IIC T6 Gb Ex tb IIIC T80 °C Db -55 °C ≤ Ta ≤ +60 °C
Certification	IECEX CML14.0029X
Ambient temperature range	-55 °C to +60 °C (-67 °F to +140 °F)
Approved for zones	1, 2 and 21, 22
Applicable Documents	<ul style="list-style-type: none"> <li>- Certificates</li> <li>- Operation instructions of the installed components</li> <li>- Delivery note (includes a list of installed components)</li> </ul> <p>The retention and observation of these documents is mandatory.</p> <p>If limited components are used, the information of the correct usage can be found on shipping documents and related certificates.</p>

## Technical data

Protection class	Up to IP66/IP67 (IEC 60529)
Rated insulation voltage	Max. AC 690 V
Rated current	Max. 16 A
Intrinsically safety parameters	Only for intrinsically safe devices: Input voltage (U): 30 V Input current (I <sub>i</sub> ): 150 mA Input Power (P <sub>i</sub> ): 1 W Inductance (L): negligible Capacitance (C): negligible
Connection type	Terminals, 2.5 mm <sup>2</sup> Torque: 0.4 Nm (0.3 lb.ft)
PE conductor terminals	4 x 2.5 mm <sup>2</sup> Torque: 0.4 Nm (0.3 lb.ft)
Cable entry	Standard version: - M20 x 1.5 for cable with Ø 7 to 13 mm (0.27 to 0.51 in) Special version: - M20 x 1.5 for cable with Ø 11 to 14 mm (0.43 to 0.55 in) - M25 x 1.5 for cable with Ø 12 to 17 mm (0.47 to 0.67 in) - M25 x 1.5 for cable with Ø 14 to 18 mm (0.55 to 0.71 in)
Enclosure material	Plastic (thermoplastic)
Enclosure Screws	M4 x 30 Torque: 0.7 Nm - 1.2 Nm (0.5 - 0.8 lb.ft)
Potential equalisation, external	M6 Torque: 3 Nm (2.2 lb.ft)
Dimensions	See page 3.

## Safety Instructions

The ComEx control and indicating devices may be used only within the specified temperature range. Unprotected, incorrect installation can cause malfunctioning and the loss of explosion proofness. Utilization in areas other than those specified or the alteration of the product by anyone other than the manufacturer will exempt BARTEC from liability for defects or any further liability. When setting up or operating explosion resistant electrical systems, the IEC/EN 60079-14 (NEC for USA/CEC for Canada) and all relevant installation and operating regulations must be observed. The generally applicable statutory rules and other binding directives relating to workplace safety, accident prevention and environmental protection must be observed. The ComEx control and indicating device may be used only if it is in a clean and undamaged condition. It is not permissible to modify the ComEx control and indicating devices in any way. If limited components are used within the device e.g. cable glands the information of correct usage can be found on shipping documents and related certificates of the component. For intrinsically safety devices an appropriate barrier has to be used. The electrical limits that are decisive for "intrinsic safety" (see accompanying documents) must be adhered to.

## Marking

Particularly important points in these instructions are marked with a symbol:



**DANGER** indicates a hazardous situation which, if not avoided, will result in death or serious injury.



**WARNING** indicates a hazardous situation which, if not avoided, could result in death or serious injury.



**CAUTION** indicates a hazardous situation which, if not avoided, could result in minor or moderate injury.



**NOTICE** is used to address practices not related to personal injury.



**NOTE** Important instructions and information on effective, economical and environmentally compatible handling.

## Standards conformed to

See EU Declaration of Conformity 01-3510-7C0001\_C

## Assembly, Installation, and Commissioning



### WARNING

#### Risk of injury due to incorrect proceedings.

- Only authorized and qualified personnel who are authorized and trained to assemble electric components in hazardous (potentially explosive) areas may do any of the assembly, disassembly, installation and commissioning work.
- Use suitable tools.

## Assembly/disassembly

Make sure the ComEx control and indicating device to be fitted is intact (no damage, no cracks).

## Installation



**NOTE** The connection has to be made in accordance with the valid operational instructions of the installation devices.

The valid operational instructions are available under: [www.bartec.com](http://www.bartec.com) or could be ordered directly from BARTEC GmbH.

Cables must be connected carefully, i.e:

- The insulation must extend up to the terminal.
- Take care not to damage the conductor.
- All screws on the connection terminals, including unused ones, must be tightened securely.
- All unused cable entries must be sealed with a certified stopper.
- It is essential to observe the necessary minimum protection level IP54 for protection against gas explosions and IP6x for protection against dust explosions. (The ComEx control and indicating devices are supplied with a minimum protection class of IP6x.)
- All cores must be connected to terminals
- approved under IEC/EN 60079-7

## Commissioning

Before commissioning check that:

- The ComEx control and indicating device has been installed in compliance with regulations.
- The ComEx control and indicating device is not damaged.
- The junction box is clean.
- The connection has been established properly.
- The cable has been laid in an orderly fashion.
- All screws are tightened securely



**NOTE** The spare parts, actuators, switching modules, and luminous modules are specified in the data sheet.

## Operation



### DANGER

#### Death or serious injury through improper use.

- The ComEx control and indicating device may be operated only within the technical limits that apply to it (see page 1).

## Transport, Storage



### NOTICE

#### ComEx control station damage through incorrect transport or incorrect storage.

- Transport and storage is permissible in original packaging only.

## Maintenance and Fault Clearance



### WARNING

#### Risk of injury due to incorrect proceedings.

- Only authorized qualified personnel may do any of the work relating to maintenance and fault clearance.
- IEC/EN 60079-17 must be observed. It is recommended to formulate a maintenance plan according to this standard.



### WARNING

#### Risk of injury because the sealing is no longer assured.

- The sealing must be replaced every time the enclosure is opened.

## Maintenance

The operator of the ComEx control and indicating device must keep it in good condition, operate it properly, monitor it and clean it regularly. The ComEx control and indicating device must be checked regularly for cracks and/or damage.

The owner/managing operator must schedule maintenance intervals which will suit the respective conditions of use.

## Fault Clearance

The ComEx control and indicating device is defective if it is damaged and/or cracked.

Defective ComEx control and indicating devices cannot be repaired; they must be replaced considering this operational instruction.

## Replacing/Fitting Components

### Installation Devices

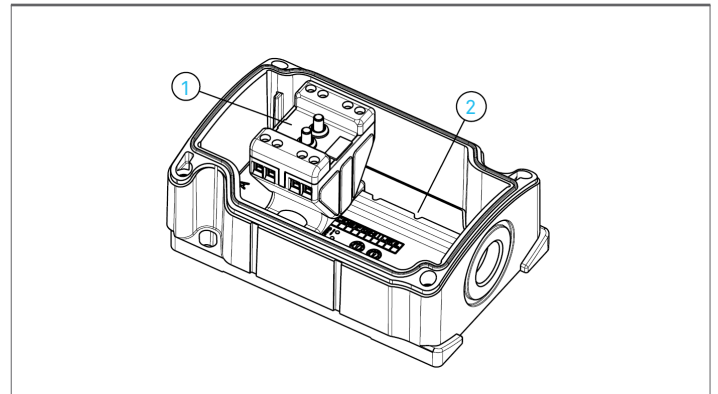

- Snap the devices (1) onto the rail of the enclosure (2) with the latch positioned in the cut-out in the rail. Please see manuals of Exchange modules.

### PE Support

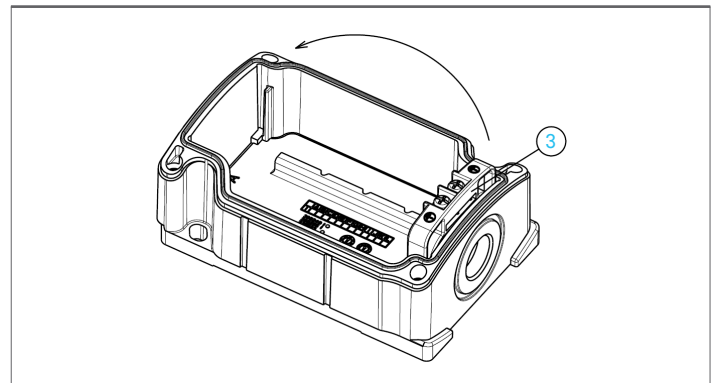

- Insert the PE support (3) for the protective conductor connection either at the top or the bottom of the enclosure.

### Earthing Plate

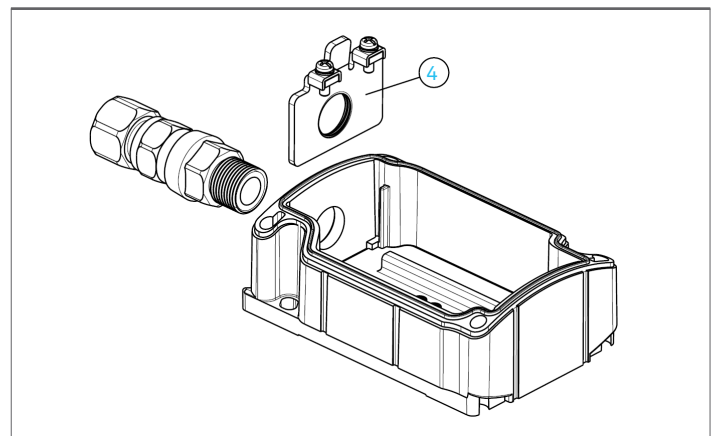

- Push the earthing plate (4) for metal cable entries in between the rib and the inside wall of the enclosure. The earthing plate is secured in place when the cable entry is screwed in.

## Actuating Element

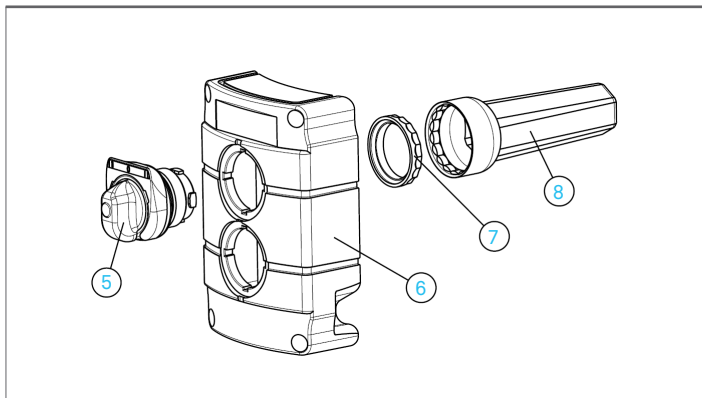

**NOTE** The position of the built-in devices must agree with the actuating element used.

- With its projecting latch positioned correctly, insert each actuating element (5) into the hole in the enclosure cover (6) and secure it in place with the retaining nut (7) using the wrench (8) (2.8 – 3.4 Nm). Please see Manual of actuating elements 05-0003-00.../....

## Position Selector Switch

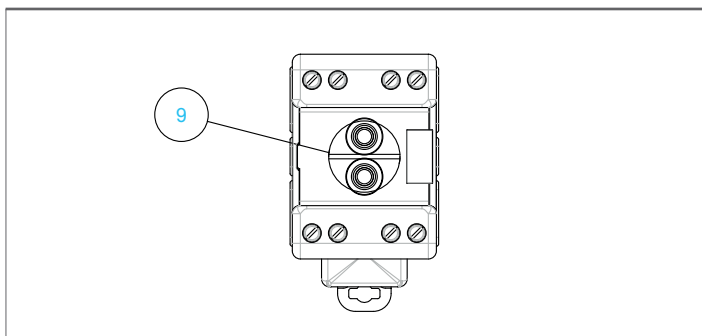

- If the actuating element being fitted is a position selector switch, make sure its actuating pins are in alignment over the metal plungers on the switch module (9).

## Label

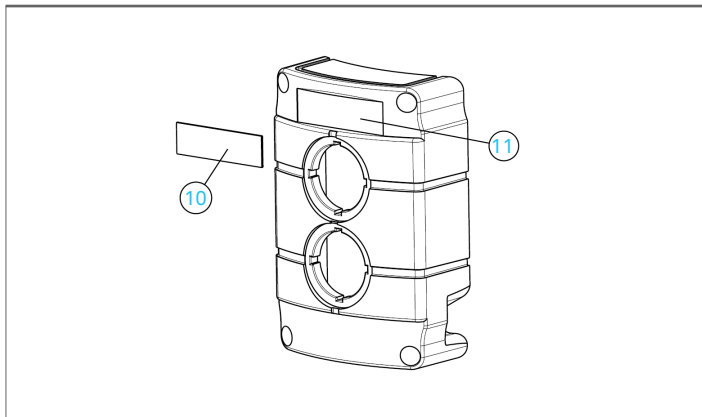

- Engrave or inscribe the labels (10) manually.
- Stuck the labels into the recess (11) provided in the enclosure cover.

## Accessories, Spare Parts

See also BARTEC catalogue.

## Disposal

The ComEx control and indicating device components (actuators, switching modules, luminous modules, enclosure) contain metal and plastic parts. Therefore the statutory requirements for disposing of electronic scrap must be observed (e.g. disposal by an approved disposal company).



## Service Address

**BARTEC GmbH**  
 Max-Eyth-Str. 16  
 97980 Bad Mergentheim  
 Germany  
 Tel.: +49 7931 597 0  
 Fax: +49 7931 597 119

## Dimensions in mm (in)

### Single unit

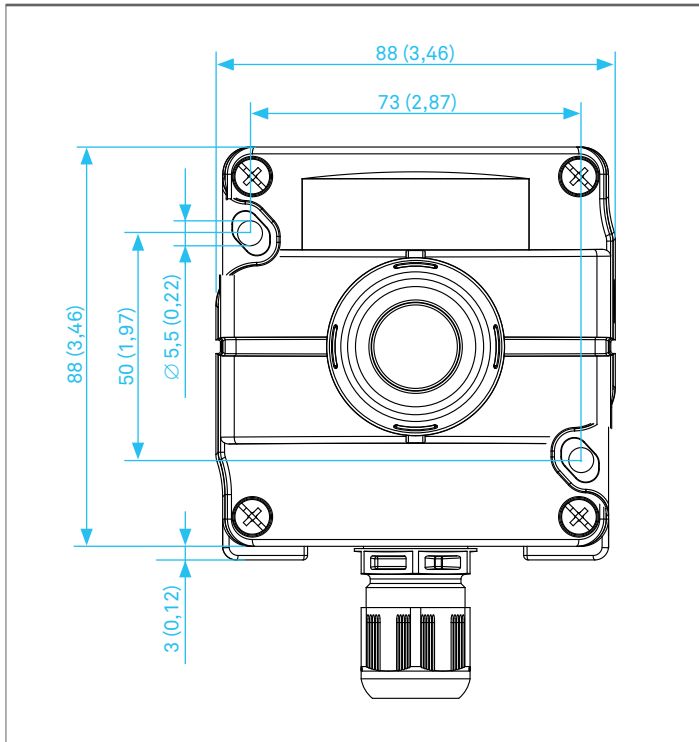

### Triple unit

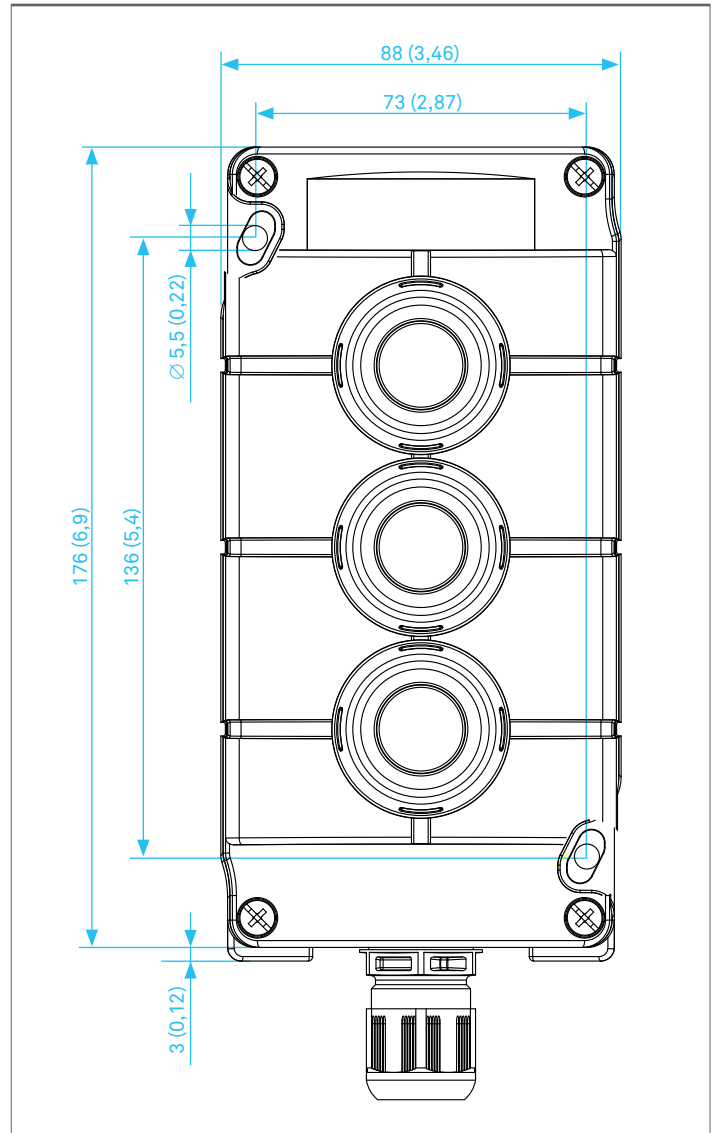

### Double unit

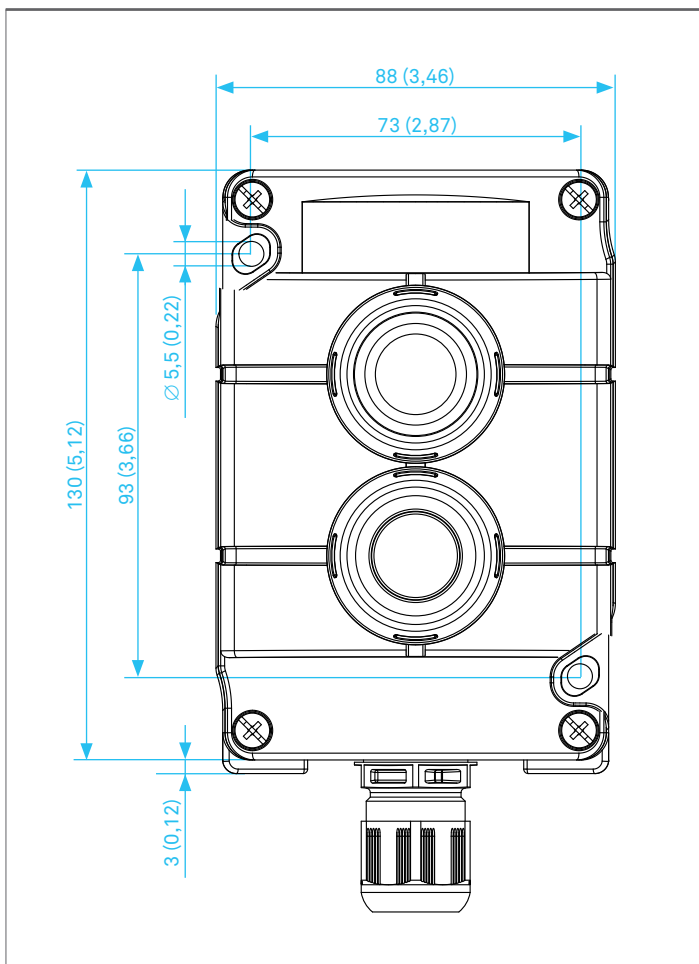

Side view

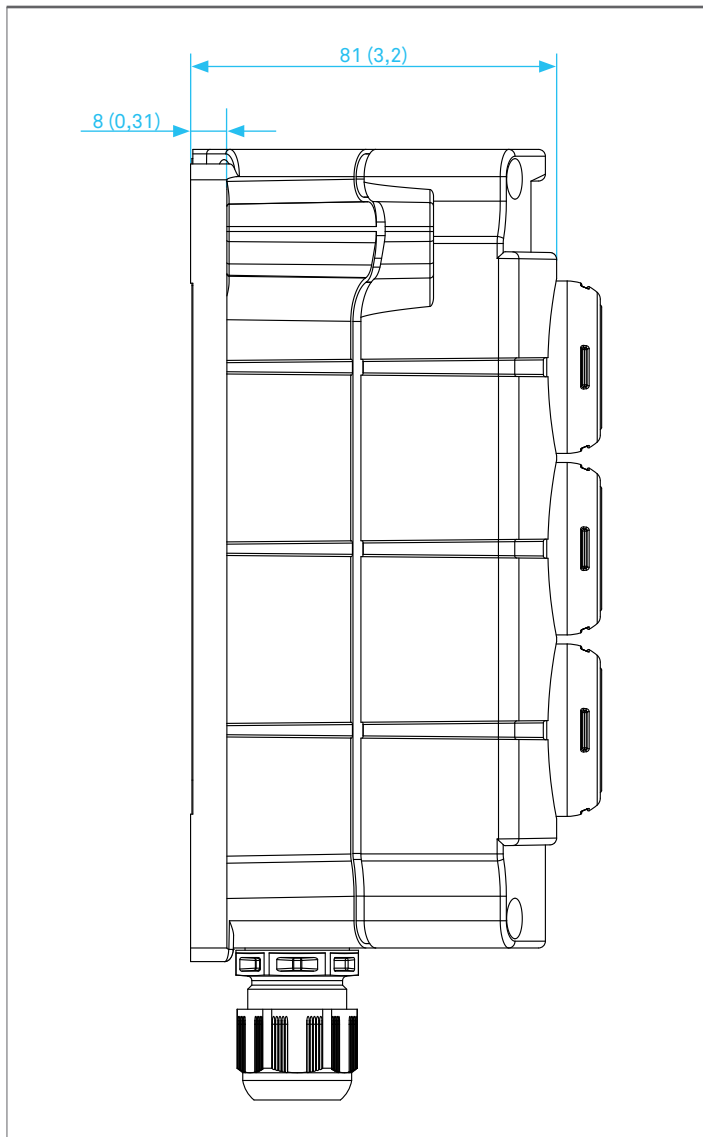



Nº 01-3510-7C0001\_C

Wir	We	Nous
<b>BARTEC GmbH,</b>		
erklären in alleiniger Verantwortung, dass das Produkt	declare under our sole responsibility that the product	attestons sous notre seule responsabilité que le produit
<b>ComEx-Befehls- und Anzeigeräte</b>	<b>ComEx control and indicating Stations</b>	<b>Appareils de commande et de signalisation ComEx</b>
<b>Typ 07-351*-*****</b>		
auf das sich diese Erklärung bezieht den Anforderungen der folgenden <b>Richtlinien (RL)</b> entspricht	to which this declaration relates is in accordance with the provision of the following <b>directives (D)</b>	se référant à cette attestation correspond aux dispositions des <b>directives (D)</b> suivantes
<b>ATEX-Richtlinie 2014/34/EU</b>	<b>ATEX-Directive 2014/34/EU</b>	<b>Directive ATEX 2014/34/UE</b>
<b>EMV-Richtlinie 2014/30/EU</b>	<b>EMC-Directive 2014/30/EU</b>	<b>Directive CEM 2014/30/UE</b>
<b>RoHS-Richtlinie 2011/65/EU</b>	<b>RoHS-Directive 2011/65/EU</b>	<b>Directive RoHS 2011/65/UE</b>
und mit folgenden Normen oder normativen Dokumenten übereinstimmt	and is in conformity with the following standards or other normative documents	et est conforme aux normes ou documents normatifs ci-dessous
<b>EN 60079-0:2012 +A11:2013</b> <b>EN 60079-1:2014</b> <b>EN 60079-7:2015</b> <b>EN 60079-11:2012</b> <b>EN 60079-31:2014</b>		<b>EN60529 :1991 +A1:2000</b> <b>+A2:2013</b> <b>EN 61000-6-2:2005</b> <b>EN 61000-6-4:2007 +A1:2011</b>
<b>Verfahren der EU-Baumusterprüfung / Benannte Stelle</b>	<b>Procedure of EU-Type Examination / Notified Body</b>	<b>Procédure d'examen UE de type / Organisme Notifié</b>
<b>CML 14ATEX3073X</b>		
<b>2503 CML, Unit 1 Newport Business Park, New Port Road, Ellesmere Port, CH65 4LZ, UK</b>		
<b>CE 0044</b>		
Bad Mergentheim, den 25.10.2018		
 Kevin Rogers Team Lead Mechanical Design ESS		 i.V. Gitta Kugler Director Global Test, Certification & IP Management